

GERMAN WWII HEAVY FIGHTER 1:72 SCALE PLASTIC KIT



eduard

ProfIPACK



intro

The first pages of history for the famous Zerstörer Bf 110 were written at the end of 1934, when C-Amt RLM (the technical branch of the Reich's Air Ministry) issued a specification for a two seat, twin engined aircraft to fulfill a need within the Kamfzerstörer category. Submitted proposals came from Focke-Wulf (Fw 57), Henschel (Hs 124) and BFW (Messerschmitt Bf 110). In the spring of 1935, the RLM changed its thinking on the spec, and cancelled the universal Kamfzerstörer category in favor of two specific types, the Schnellbomber and the Zerstörer. The new concept of a heavy fighter of the RLM were best satisfied by the Messerschmitt design, which wasn't really dictated as much by the original specifications. The first prototype, the Bf 110 V1, first flew May 12, 1936, and the modified second prototype V2 was submitted to the Erprobungstelle in Rechlin on January 14, 1937. Four development aircraft, A-01 to A-04, powered by JUMO 210Da engines, were delivered at the beginning of 1938. A production run of 45 Bf 110Bs began in July, powered by JUMO 210Ga engines, delivering some 500kW (680hp). At the end of 1938, the production line for the high performance DB 601 finally got going, and these were mounted into the first major Bf 110 version, the Bf 110C. The Bf 110C, as was the case with the Bf 110B, was armed with two MG FF cannon, mounted in the fuselage below the cockpit floor, four MG 17 machine guns mounted in the nose and one rear firing MG 15 machine gun manned by the gunner/radio operator. There was a crew of two. The Luftwaffe received a total of 169 Bf 110Cs by September, 1939. The first combat experience of the type in Norway and France uncovered a small operational radius, unsuitable for an escort fighter. The first attempt to remedy the shortcoming came in the form of a large, underfuselage conformal type external fuel tank, called the Dackelbauch. The Bf 110C-3, adapted to carry this tank, were redesignated D-0. Results were not entirely satisfactory with the D version, and so there was a reconstruction of the fuel system, after which aircraft of the D version carried two drop tanks under the wings, and a small oil tank under the fuselage. The Bf 110D also standardized a longer fuselage, by way of an extension at the rear carrying a life raft and other emergency survival gear. This was a feature also evident on some subsequent Bf 110Es, which were equipped with bomb racks under the fuselage and wings. The majority of Bf 110Es were powered by the DB 601N engines. The following Bf 110F received the DB 601F engines housed in reshaped nacelles, with newer, more rounded spinners, aerodynamic features taken from the Bf 109F. Upgrading efforts were noted in the armament as well, where the MG FF were replaced by MG 151s. Significant changes came with the Bf 110G, powered by new DB 605 engines. The rear firing MG 82Z double gun appeared on the G-2, and with the G-4 came the replacement of four forward firing machine guns with two 30mm MK 108 cannon. The G-4 also saw larger rudders mounted.

The Bf 110 went through not only technical changes throughout its career, but also through a development of its operational use. It entered the war as a heavy escort and attack fighter. By the time of the Battle of Britain, it became apparent that the aircraft, in the role of escort fighter, had been pushing the envelope of its capabilities. On the contrary, as a defensive weapon against British bombers, the Bf 110 made an extremely good showing of itself, and remained a deadly foe through to the end of the war. The placement of RAF bombing operations within nighttime hours from 1941 brought the Bf 110 into the realm of nightfighting on the Western Front. On the Eastern Front, they excelled as fast fighter bombers. Their earlier role as a day attack fighter was still fulfilled not only on the Eastern Front (where they were employed throughout the war successfully even as the originally envisioned escort fighter), but also on the Western Front into the depths of the summer of 1944, where the role was abandoned primarily, and finally, due to the effectiveness of American fighter escorts. As a nightfighter in the G-4 version, thanks to a heavy forward firing armament and radar, they soldiered on literally until the very end of the war. As such, it was the nightfighter role that would prove to be the most significant for the Bf 110 during the course of the Second World War.

E Bf 110C, W.Nr.3602, Stab II./ZG76, flown by Maj. Erich Groth

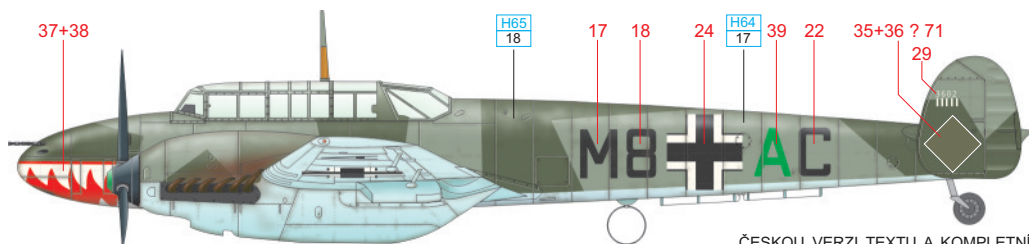

ATTENTION



UPOZORNĚNÍ



ACHTUNG



ATTENTION



注意



Carefully read instruction sheet before assembling. When you use glue or paint, do not use near open flame and use in well ventilated room. Keep out of reach of small children. Children must not be allowed to suck any part, or pull vinyl bag over the head.



Před započatím stavby si pečlivě prostudujte stavební návod. Při používání barev a lepidel pracujte v dobře větrané místnosti. Lepidla ani barvy nepoužívejte v blízkosti otevřeného ohně. Model není určen malým dětem, mohlo by dojít k požití drobných dílů.

INSTRUCTION SIGNS ✳ INSTR. SYMBOLY ✳ INSTRUKTION SINNBILDEN ✳ SYMBOLES ✳ 記号の説明

OPTIONAL
VOLBABEND
OHNOUTOPEN HOLE
VYVRTAT OTVORSYMETRICAL ASSEMBLY
SYMETRICKÁ MONTÁŽNOTCH
ZÁREZREMOVE
ODRŮZNOUTAPPLY EDUARD MASK
AND PAINT
POUŽIT EDUARDS MASK
NABARVIT

PARTS



DÍLY



TEILE



PIĚCES



部品

PLASTIC PARTS

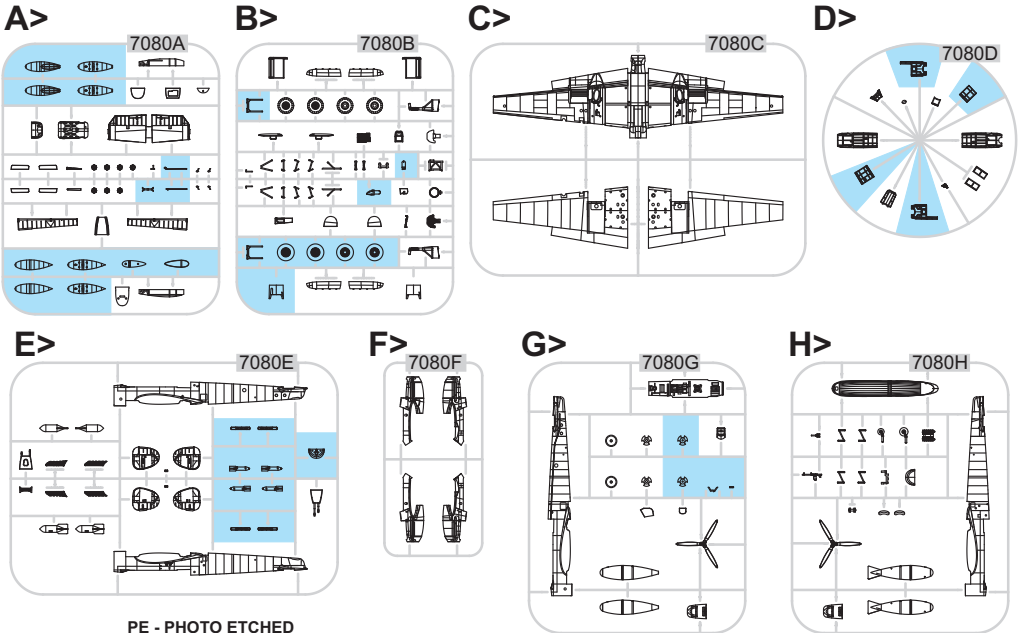
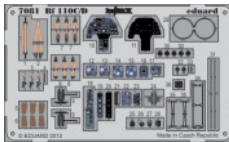
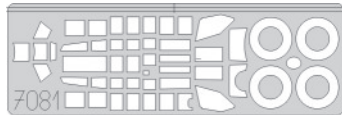
PE - PHOTO ETCHED
DETAIL PARTSeduard
MASK

Parts not for use. -Teile werden nicht verwendet. -Pièces à ne pas utiliser. -Tyto díly nepoužívejte při stavbě. - 使用しない部品

COLOURS



BARVY



FARBEN



PEINTURE



色

GSI Creos (GUNZE)			
AQUEOUS	Mr.COLOR		
[H 3]	C3	RED	
[H 4]	C4	YELLOW	
[H 6]	C6	GREEN	
[H 11]	C81	FLAT WHITE	
[H 12]	C33	FLAT BLACK	
[H 33]	C81	RUSSET	
[H 37]	C43	WOOD BROWN	
[H 47]	C41	RED BROWN	
[H 84]	C17	DARK GREEN	RLM71

AQUEOUS	Mr.COLOR		
[H 65]	C18	BLACK GREEN	RLM70
[H 67]	C116	LIGHT BLUE	RLM65
[H 70]	C60	GRAY	RLM02
[H 77]	C137	TIRE BLACK	
[H 80]	C54	KHAKI GREEN	
[H 416]	C116	BLACK GRAY	RLM66
Mr.METAL COLOR			
	[MC214]	DARK IRON	
	[MC219]	BRASS	

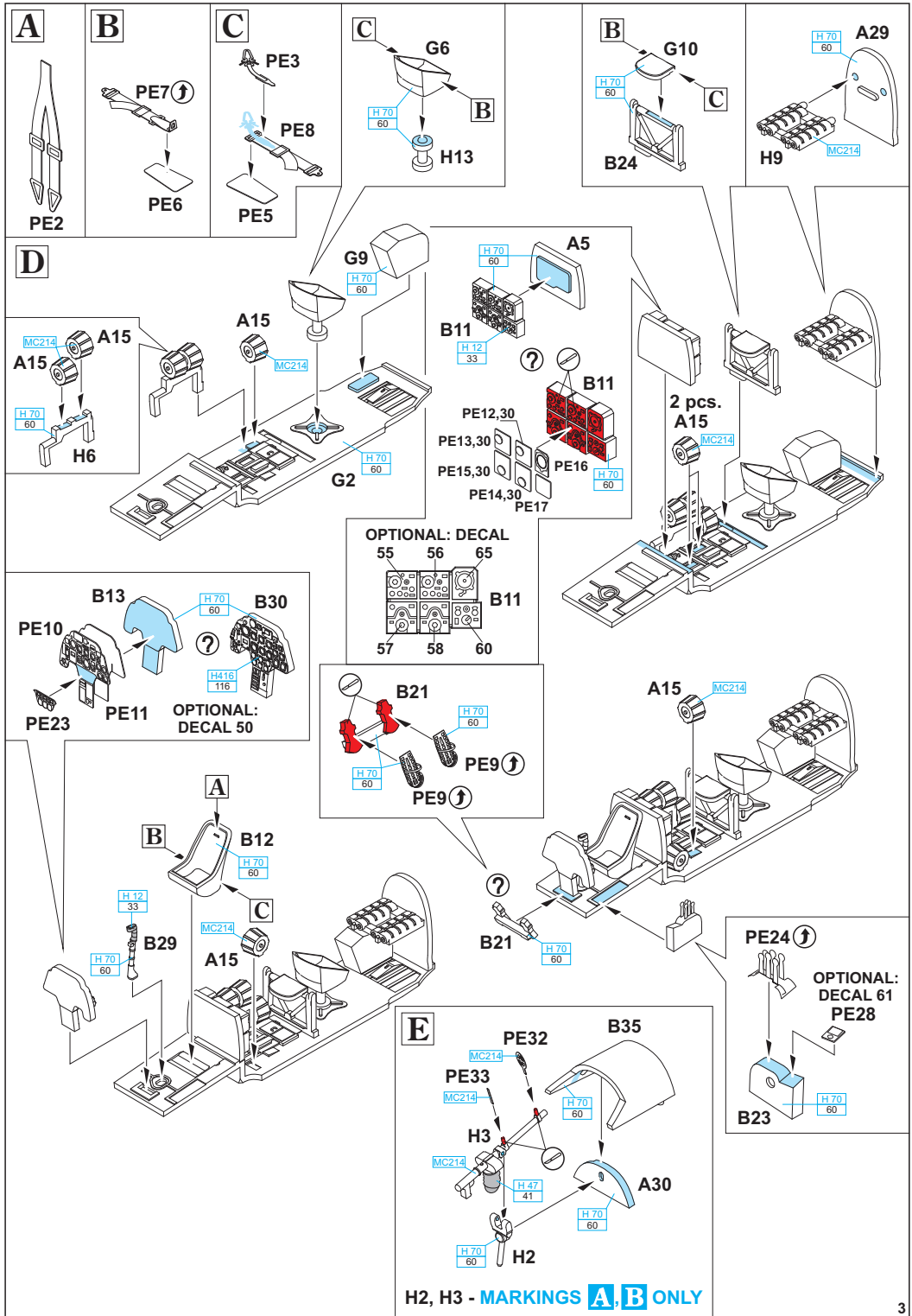

H2, H3 - MARKINGS **A, B** ONLY

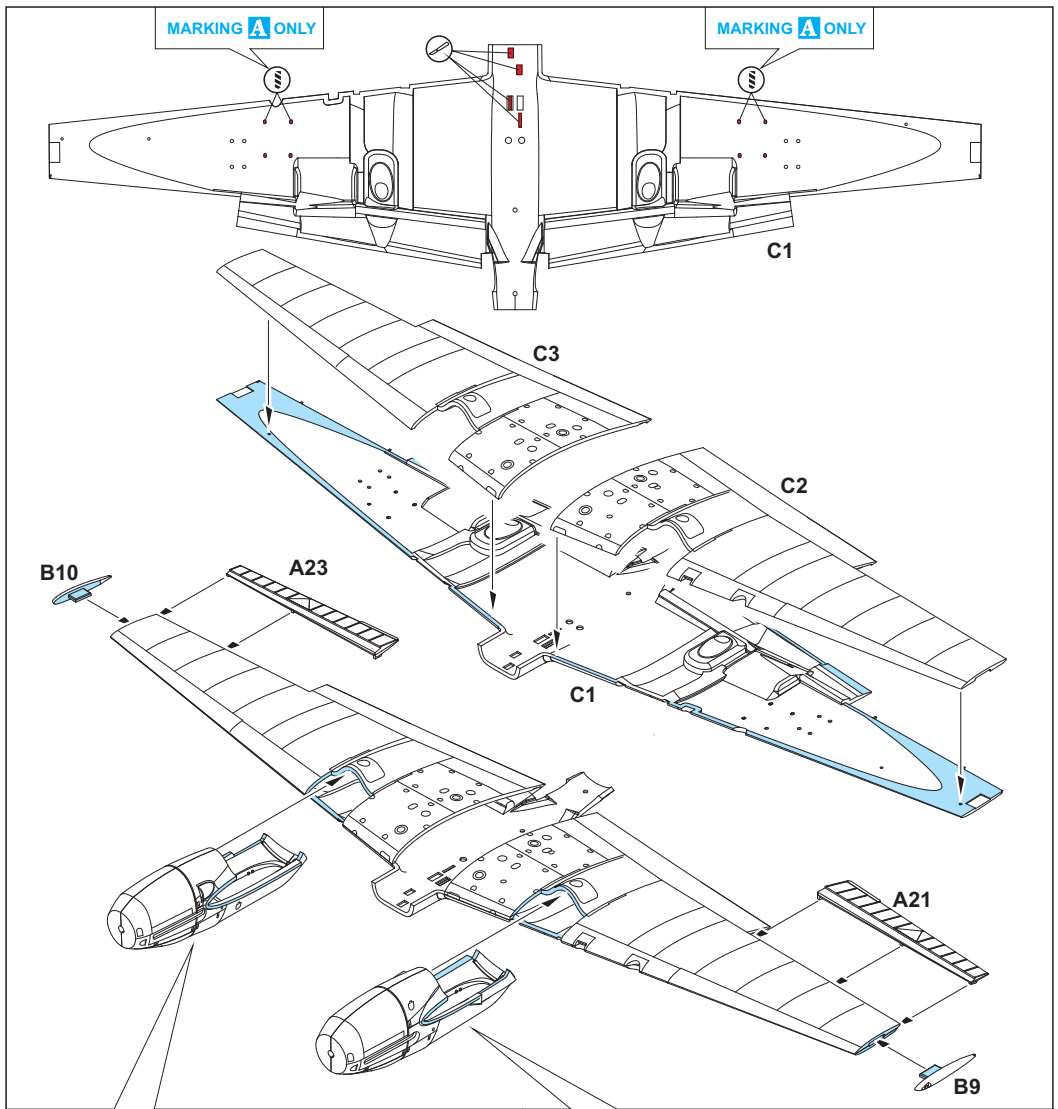

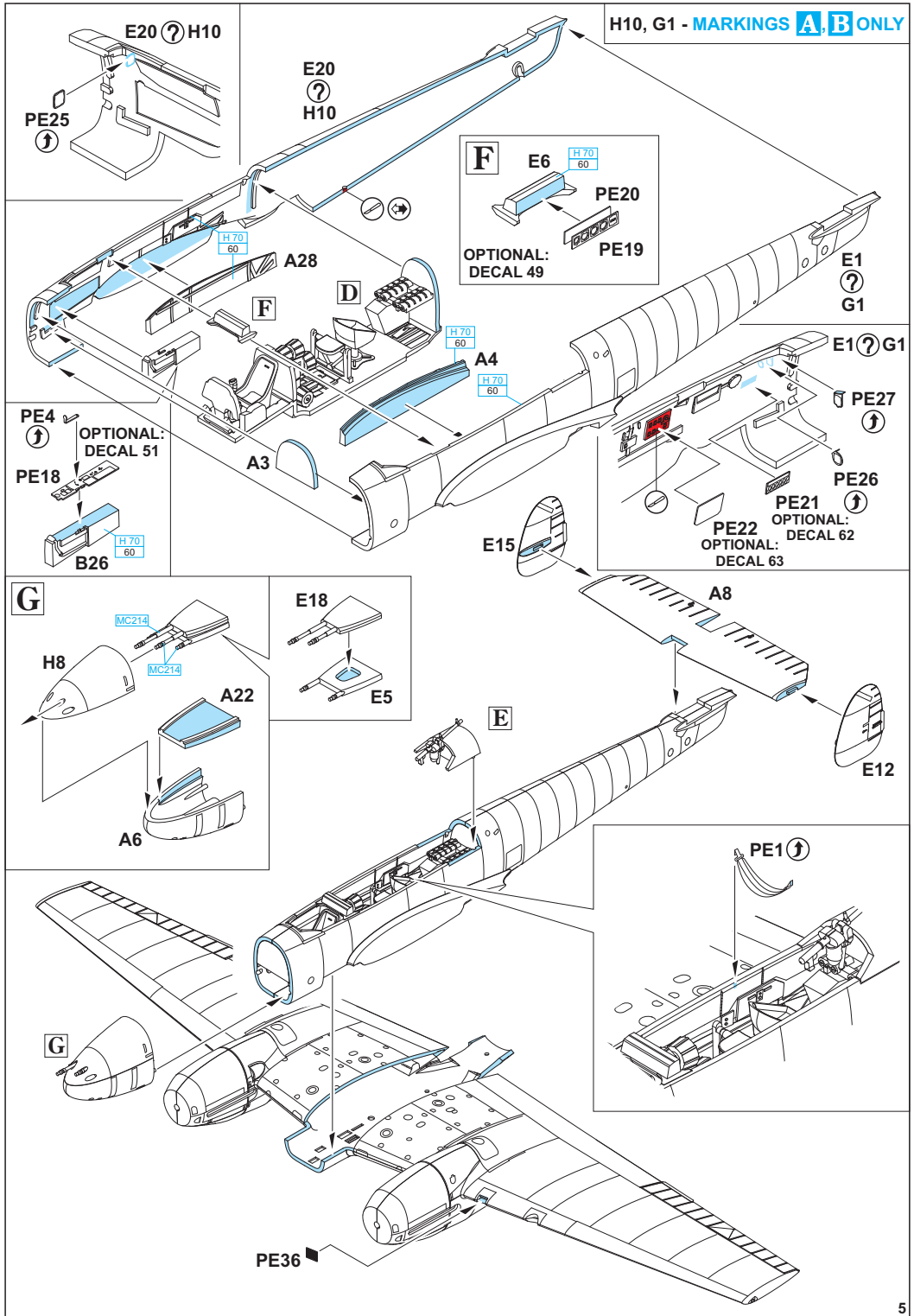

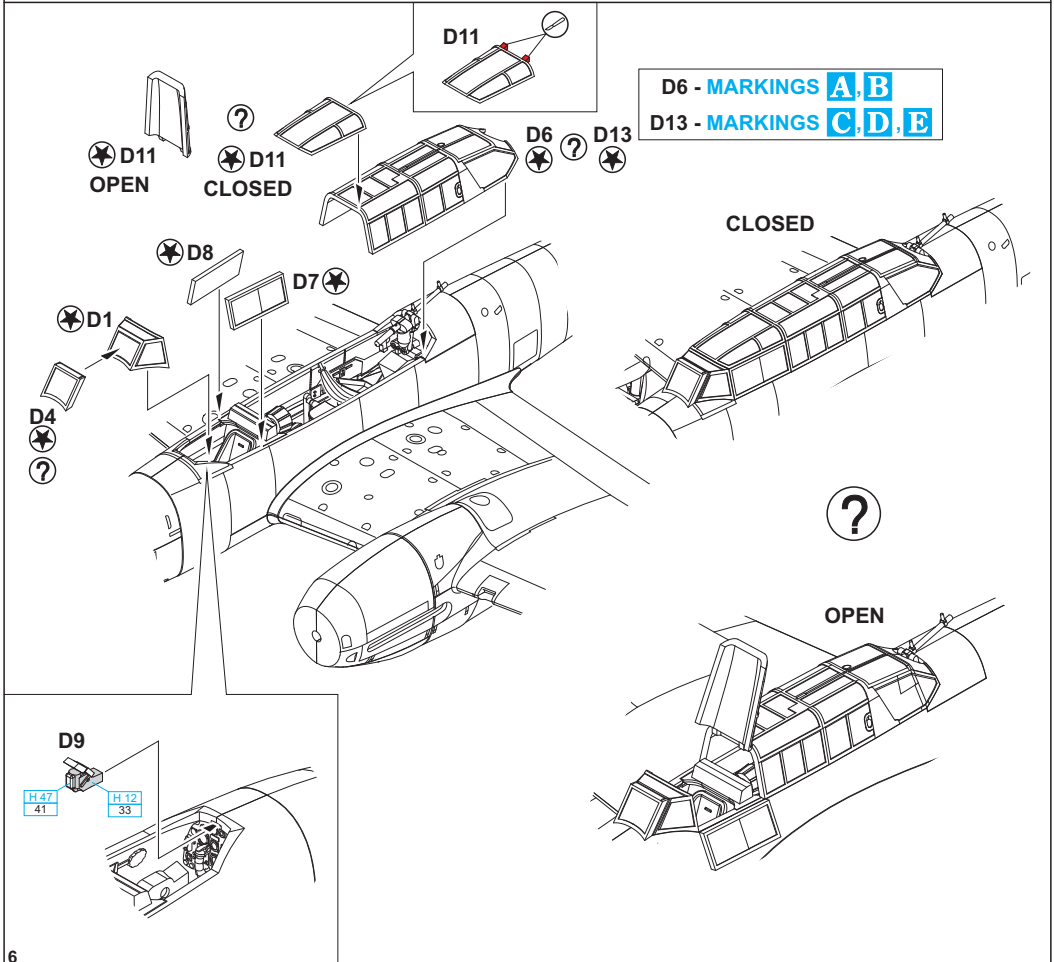
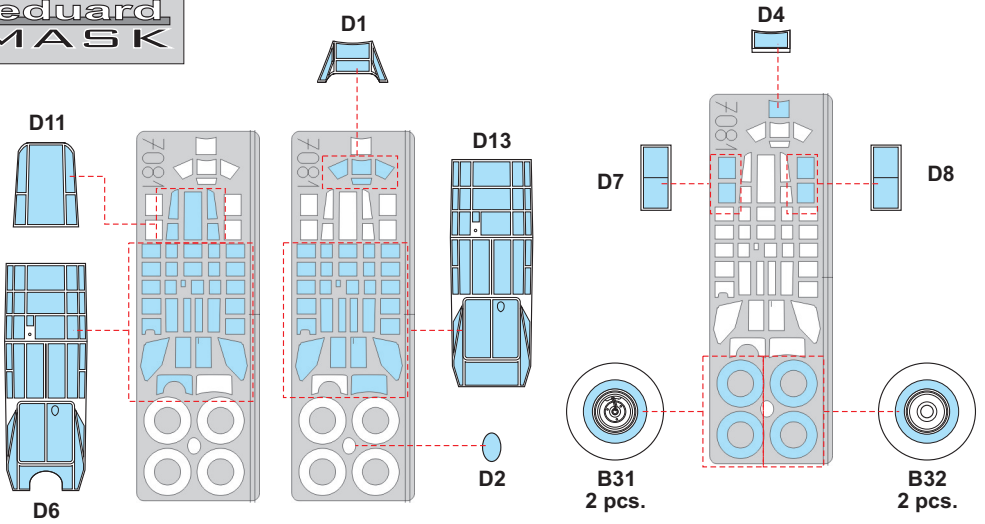

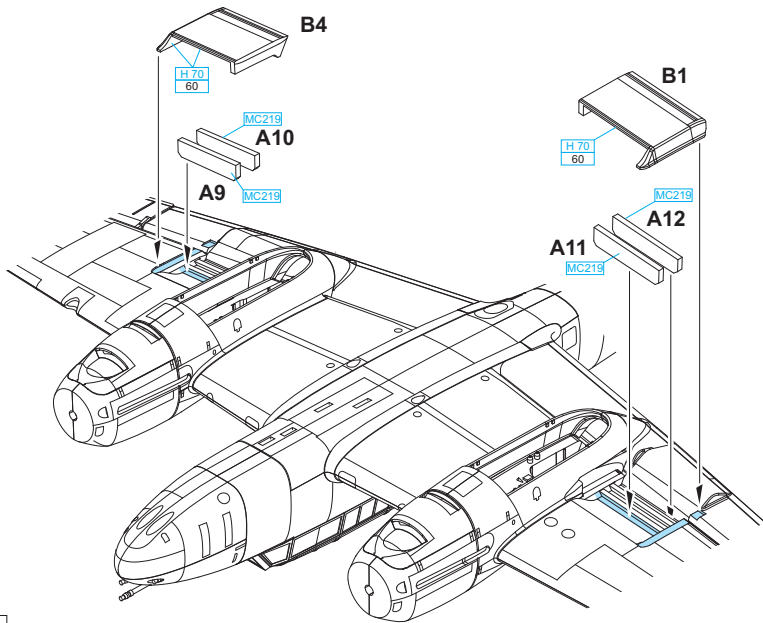

B19

B8

H 47
41

H 70
60

H 70
60

PE35



B15

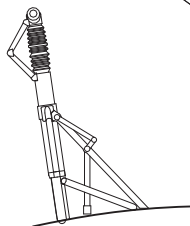
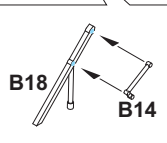
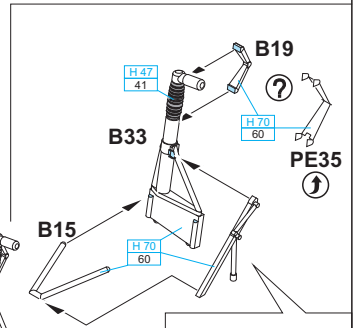

SIDE VIEW

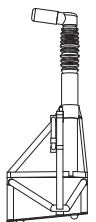
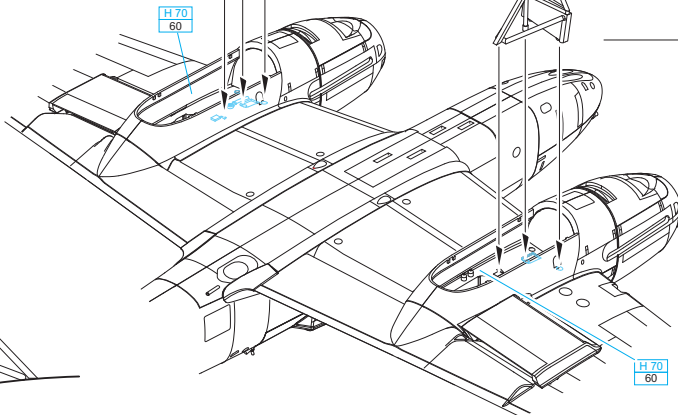

REAR VIEW

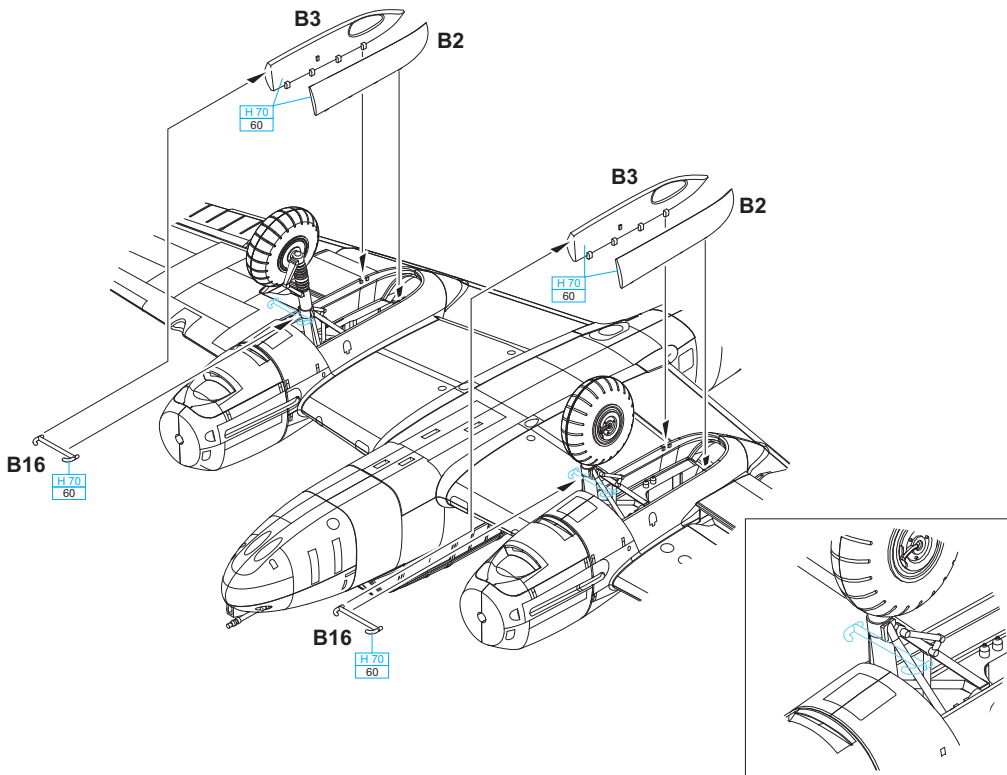
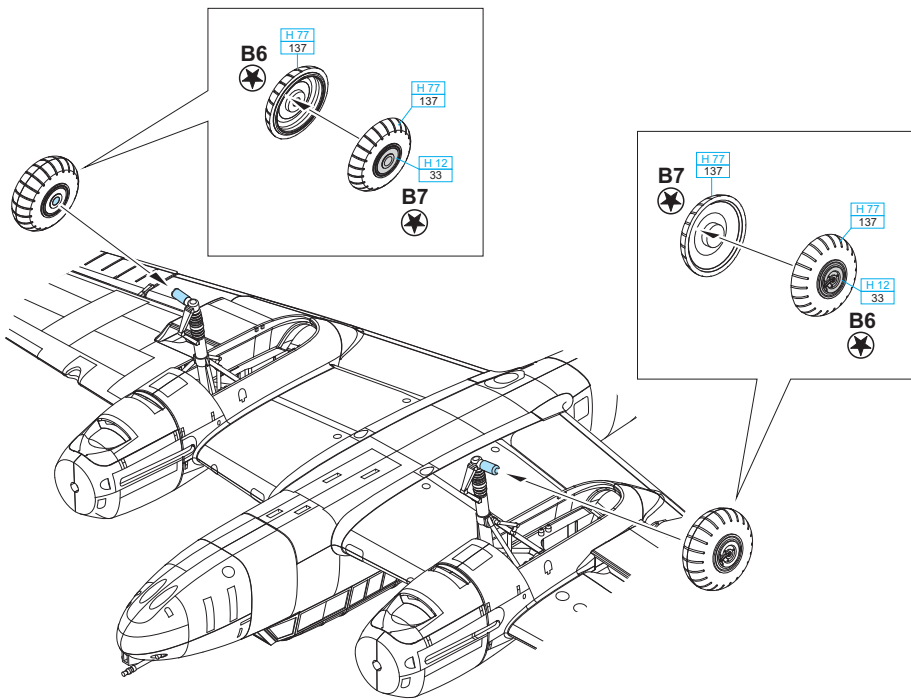

H7 - MARKINGS **A, B**

H5 - MARKINGS **C, D, E**

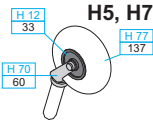

H5
H7

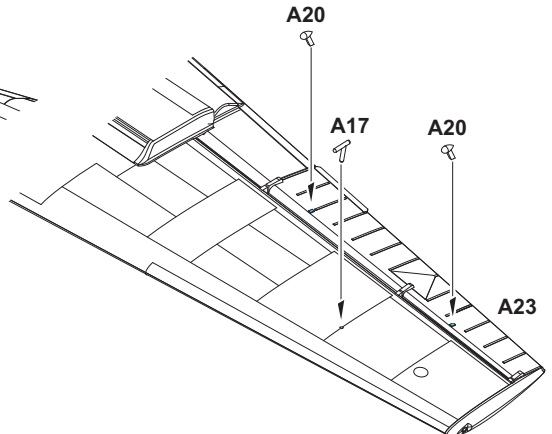
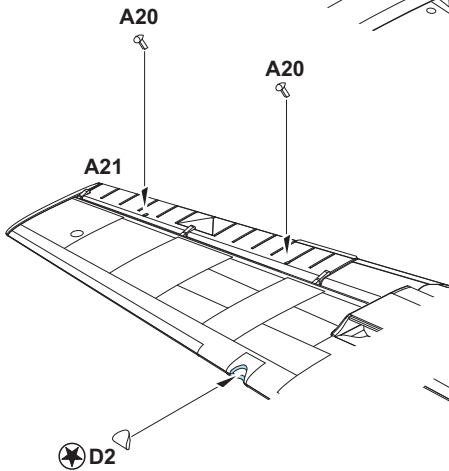
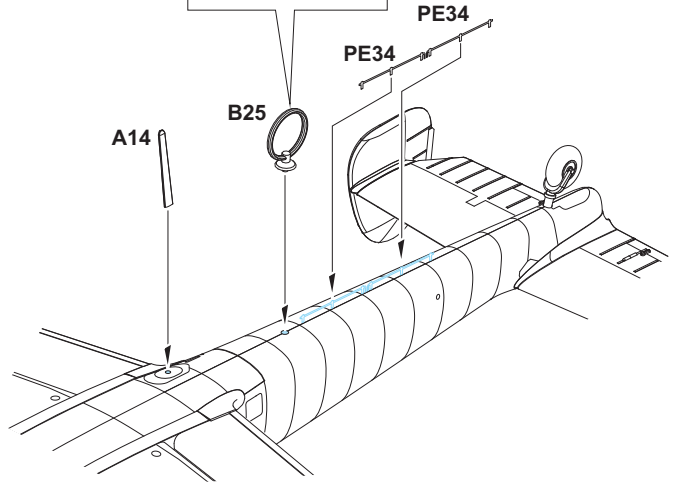
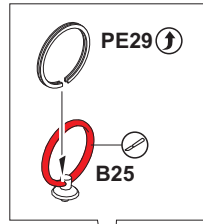
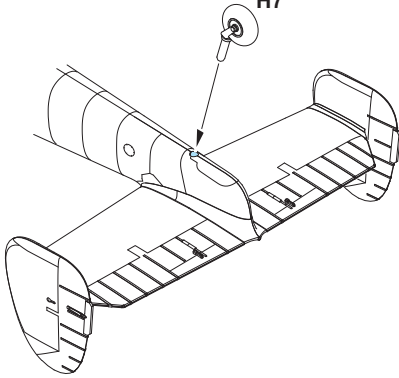

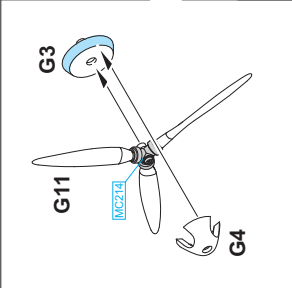
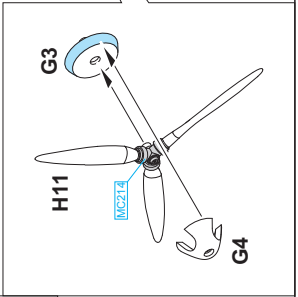
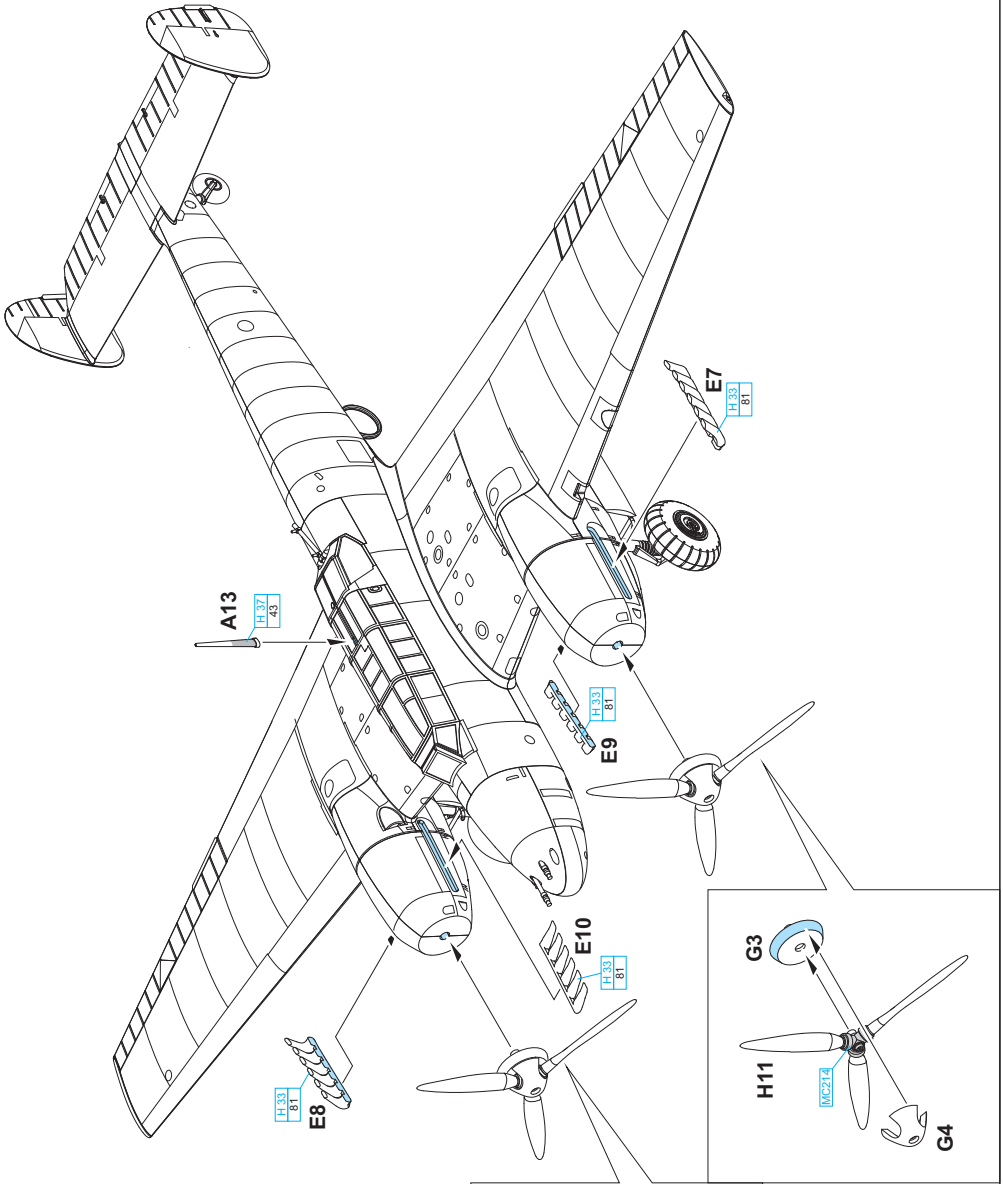

THE CROSS - SECTION

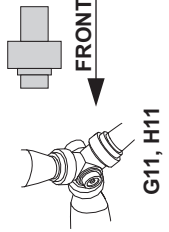

G11, H11

MARKING
A ONLY

J

MARKING
B ONLY

H1

MARKING
A ONLY

H 2 pcs.

PE31

H400
54

H400
54

E13

A7

MARKING
A ONLY

J

H 2 pcs.

E2

E19

J 2 pcs.
G13

FRONT EDGE OF THE FUSELAGE RACK
FOLLOWS THE PANEL LINE

H15

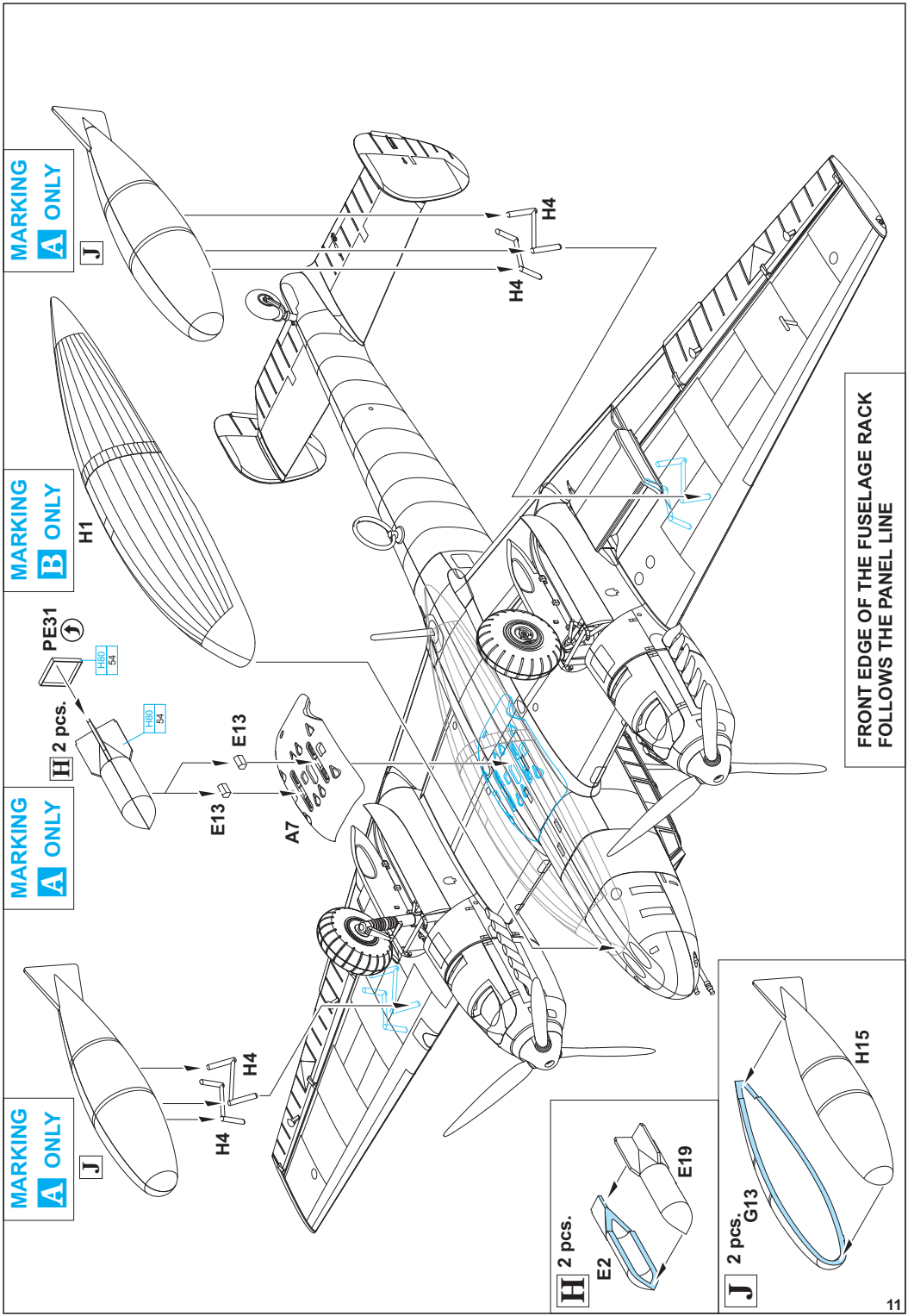

A Bf 110D, W.Nr. 3406, 9./ZG 26, Trapani, Sicily, 1941

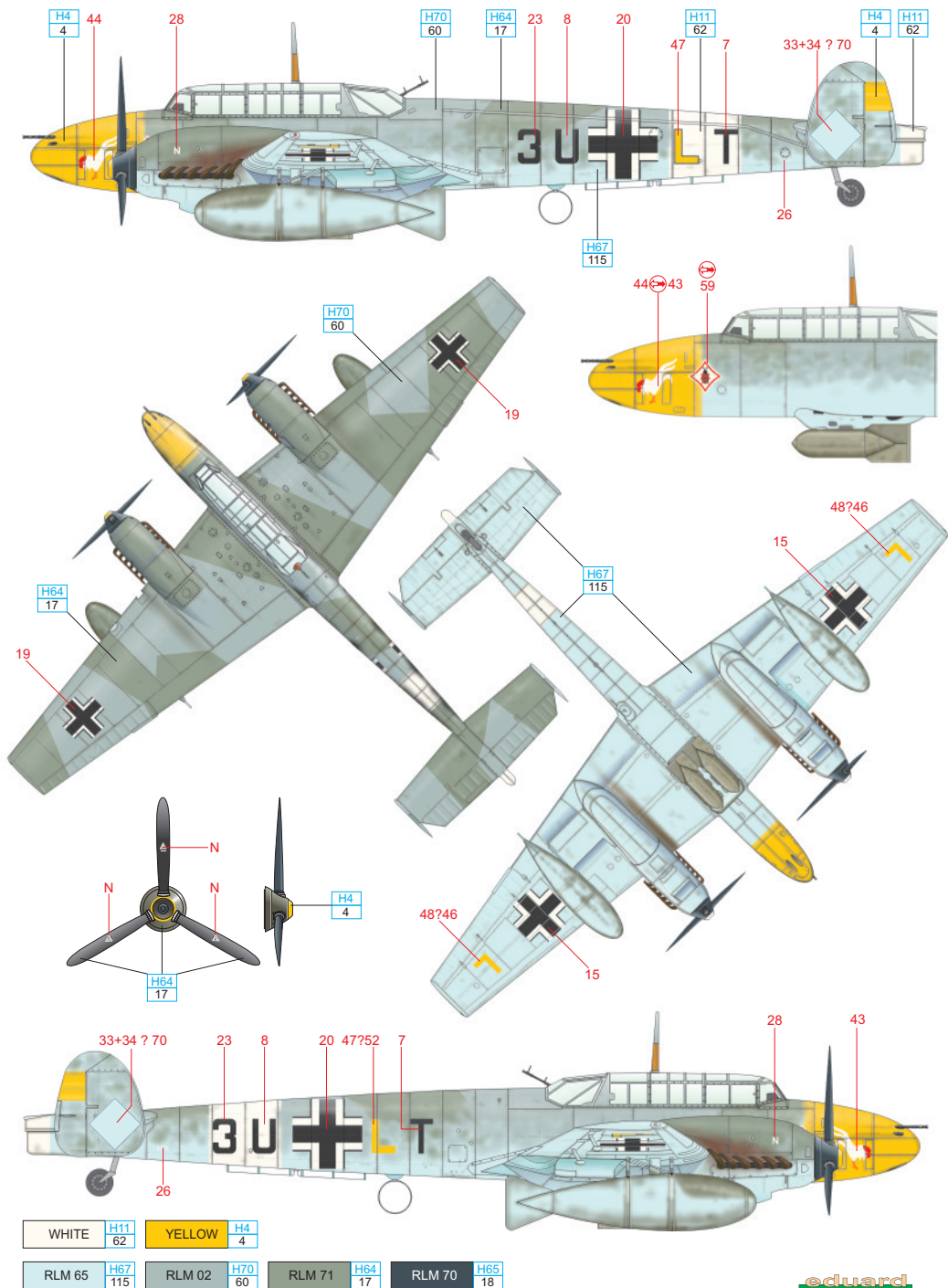

B Bf 110D, W.Nr. 3148, 2./ZG 76; Norway, spring 1940

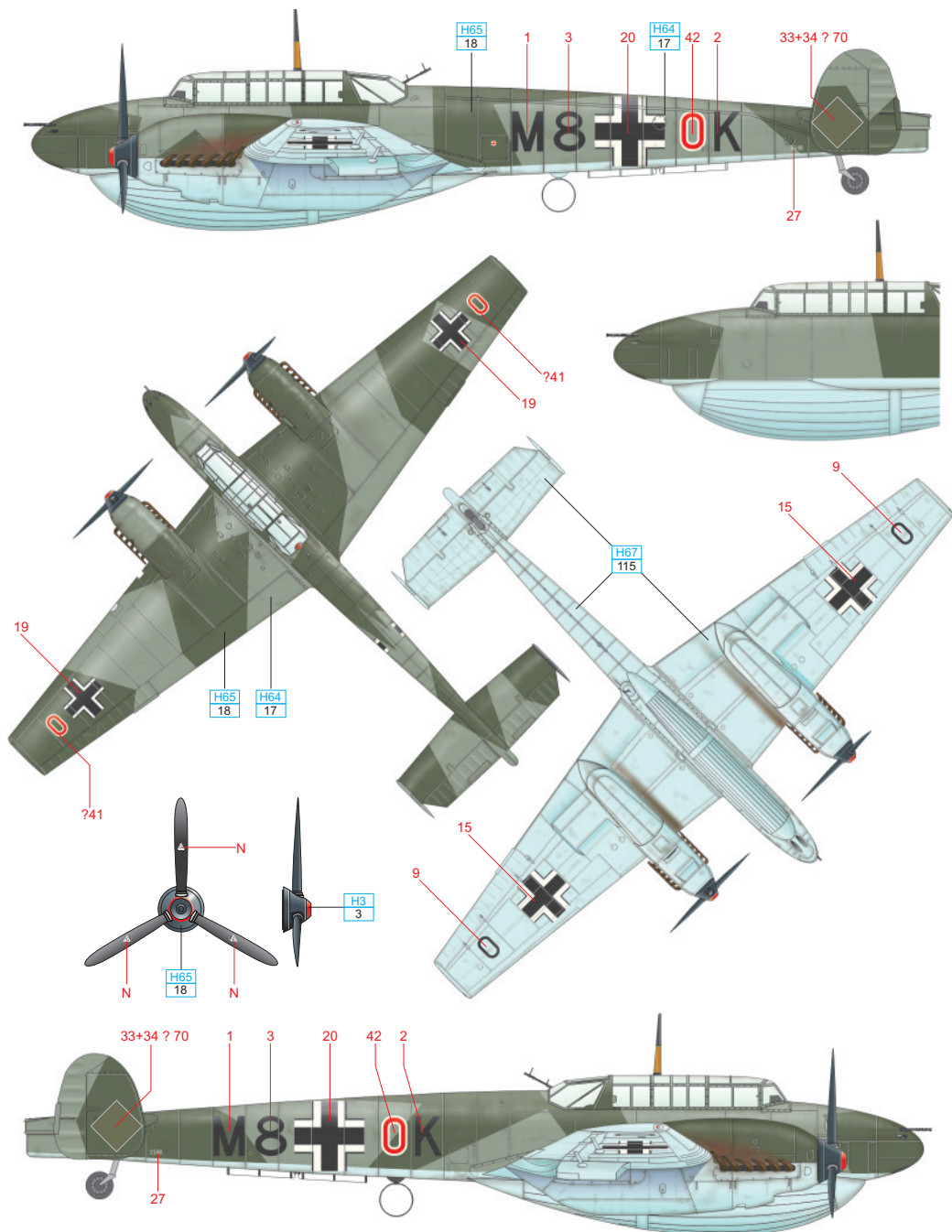

RLM 65	H67 115	RLM 71	H64 17	RLM 70	H65 18	RED	H3 3
--------	------------	--------	-----------	--------	-----------	-----	---------

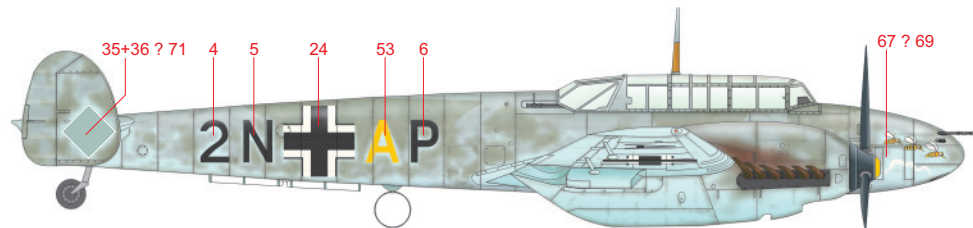
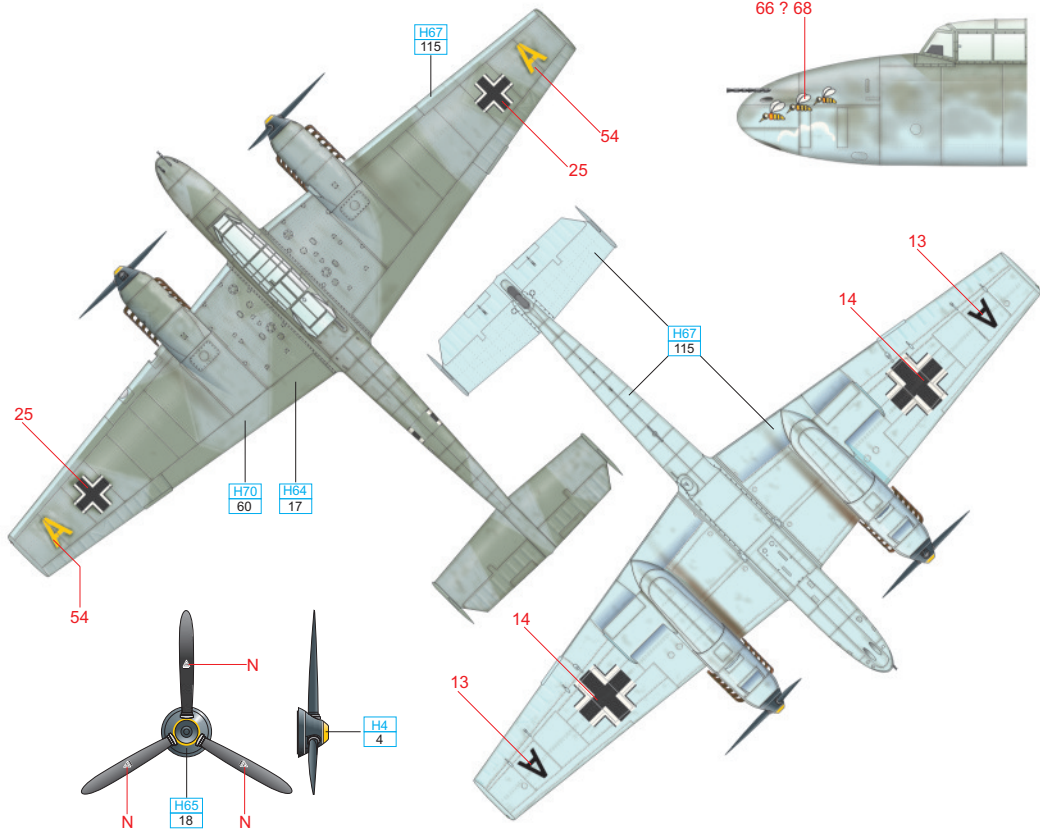
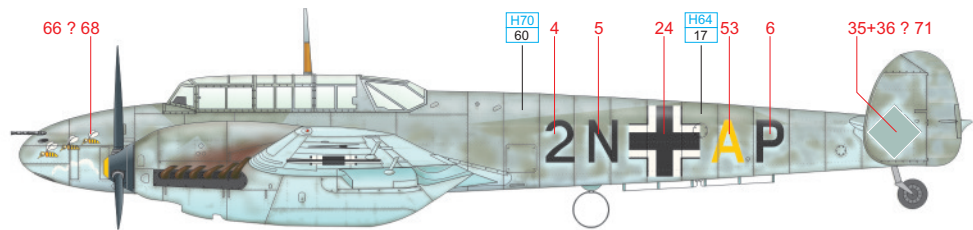

YELLOW H4 4

RLM 65 H67 115

RLM 02 H70 60

RLM 71 H64 17

RLM 70 H65 18

D Bf 110C, 1./NJG3, North Africa, summer, 1941



WHITE	H11 62
-------	-----------

RLM 65	H67 115
--------	------------

RLM 02	H70 60
--------	-----------

RLM 71	H64 17
--------	-----------

RLM 70	H65 18
--------	-----------

RLM 22	H77 137
--------	------------

E Bf 110C, W.Nr.3602, Stab II./ZG76, flown by Maj. Erich Groth

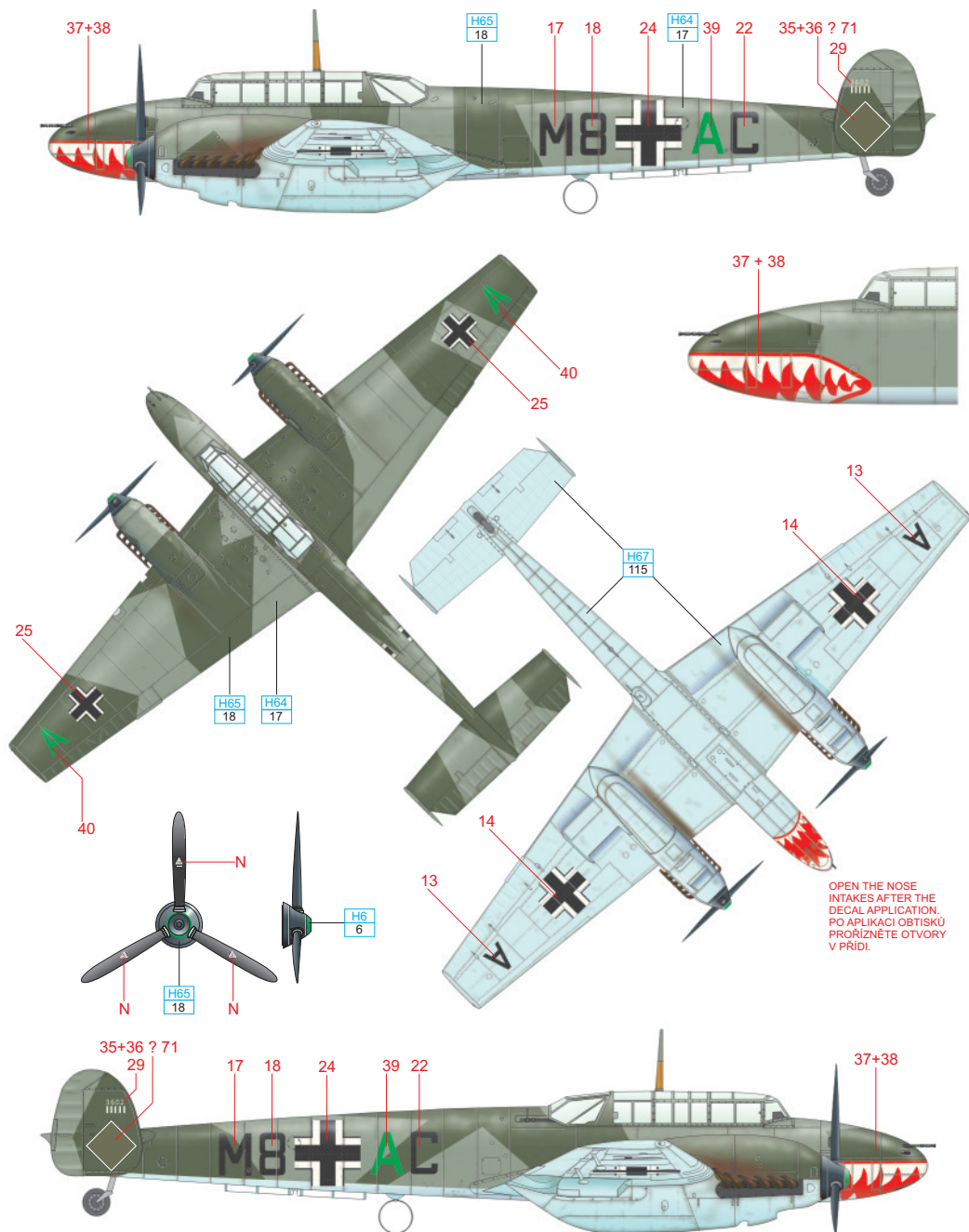

RLM 65	H67 115	RLM 71	H64 17	RLM 70	H65 18	GREEN	H6 6
--------	------------	--------	-----------	--------	-----------	-------	---------

